

Transit Mixers

P 7+ | P 8 PTO | P 9 PTO | P 10 PTO



23 % bigger feeder hopper for fast and spillage free concrete loading



Highest in class, 18-litre hydraulic oil cooler system for optimal performance



32 % bigger discharge chute for faster concrete discharge



72 CC / 90 CC hydraulic motor provides higher torque for tough concrete mixes



Box frame with a yield strength of 530 N/mm², highest in its segment

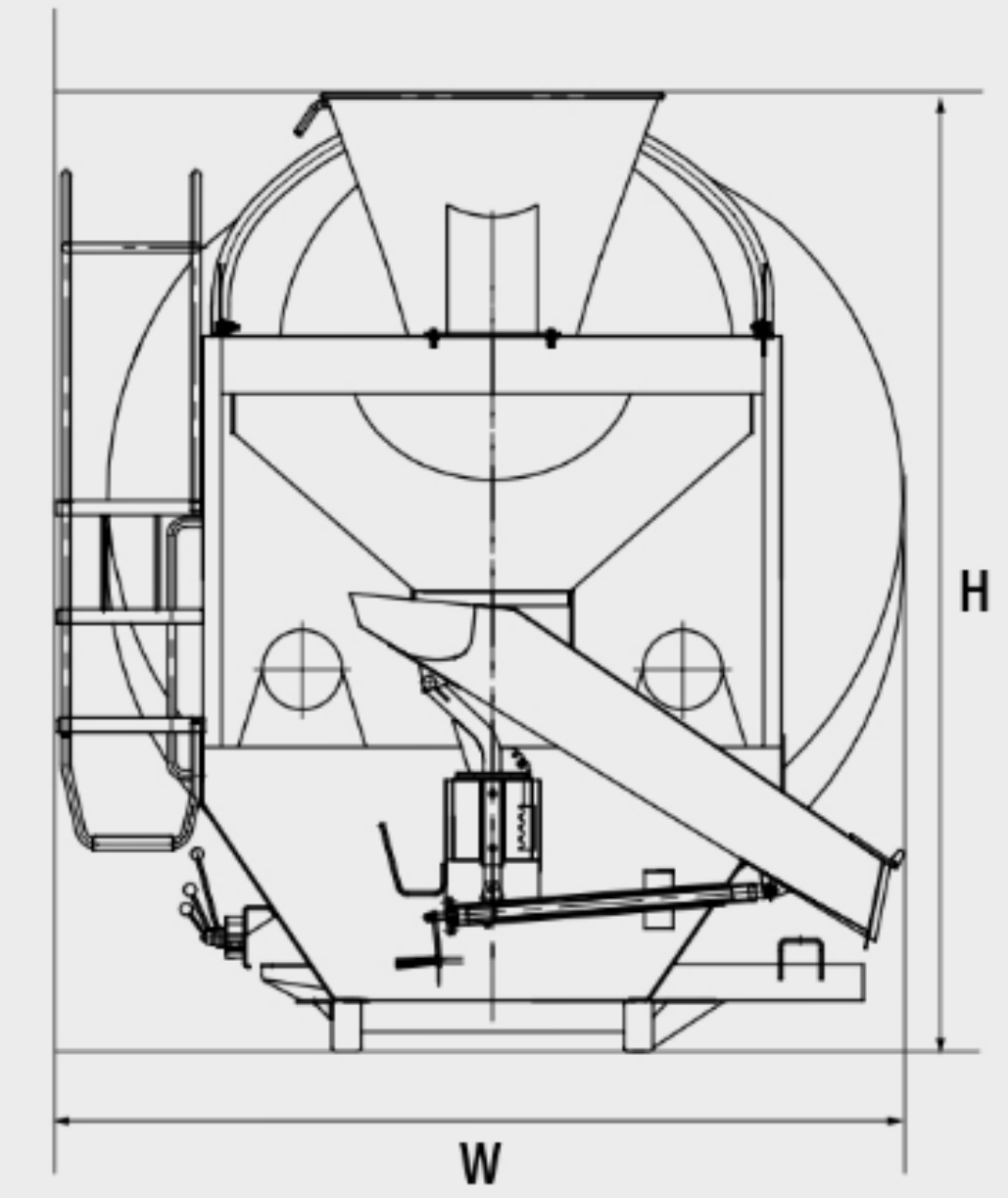
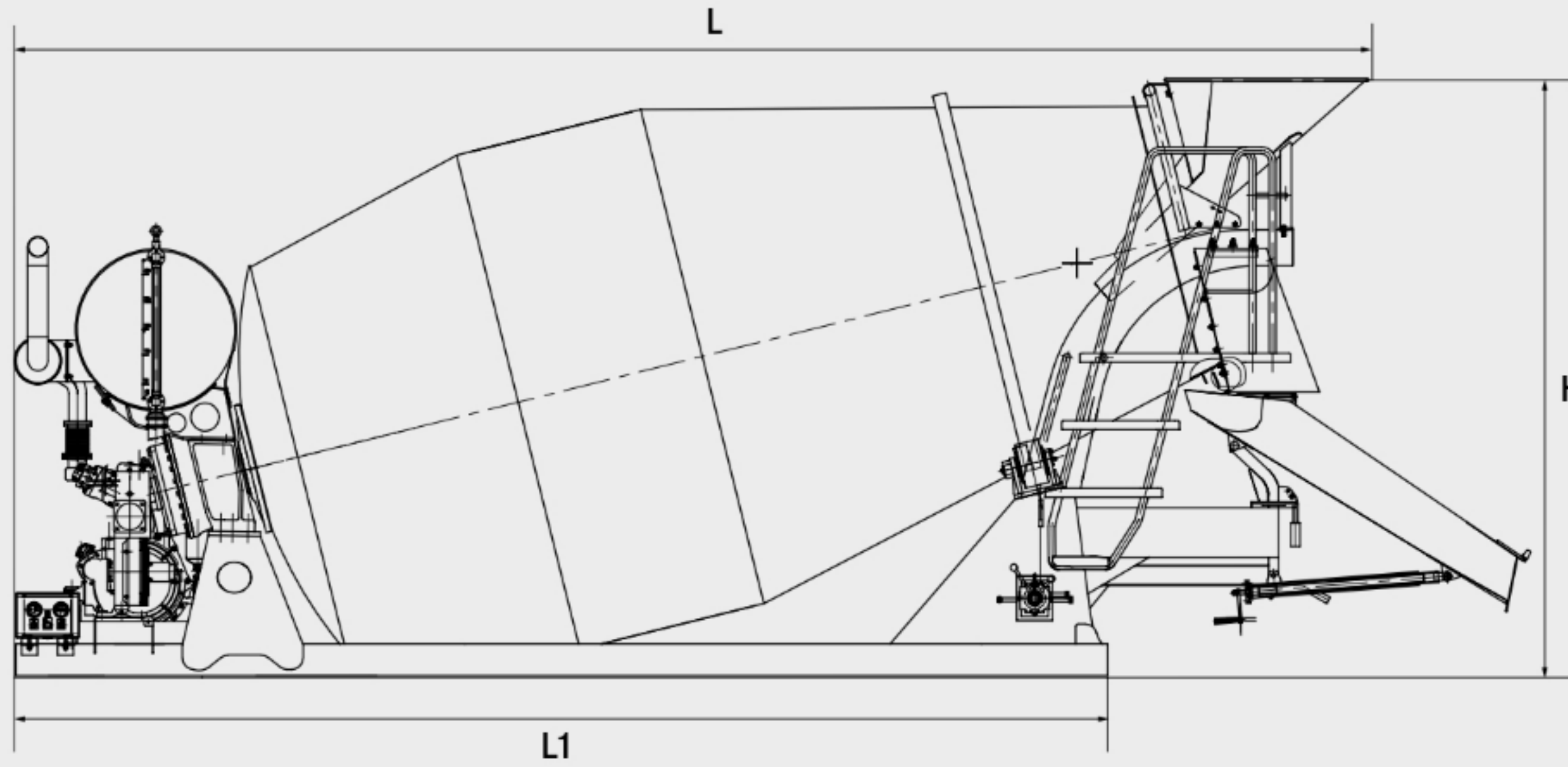

Parameters	Units	P 7+	P 8 PTO	P 9 PTO	P 10 PTO
Nominal Filling Capacity	L (m ³)	7000 (7)	8000 (8)	10000 (10)	10000 (10)
Waterline Volume	L	8260	8970	10500	10800
Geometric Volume	L	12730	14250	16500	17500
Filling Ratio	%	64.8	56.1	56.9	57.1
Drum Speed	rpm	0-14	0-14	0-14	0-14
Max Drum Diameter	mm	2260	2260	2260	2260
Installation Angle	Deg	14	13	12	12
Water Tank Capacity	L	450	500	500	600
Drive Unit	Type	Slave Engine	EPTO	EPTO	EPTO
Rotational Direction (Loading)		Anti-Clockwise	Anti-Clockwise	Anti-Clockwise	Anti-Clockwise
Rotational Direction (Discharging)		Clockwise	Clockwise	Clockwise	Clockwise
Length - L	mm	6385	6400	7400	7248
Length - L1	mm	4900	5300	6000	6100
Height - H	mm	2670	2730	2750	2750
Width - W	mm	2390	2390	2390	2390
Weight	kg	3800	4200	4650	4950

Putzmeister Concrete Machines Pvt. Ltd.

Plot No. N4, Phase 4, Verna Industrial Estate,
 Salcette - Goa 403 722. INDIA
 Tel.: +91 (832) 6696 000 · Fax: +91 (832) 6696 300
 Whatsapp: +91 91585 34123 · www.putzmeister.com



For all your support needs, contact.india@putzmeister.com

Regional Offices: NORTH: 011 4200 5600, EAST: 033 6614 2525, WEST: 022 2636 0181 / 82, SOUTH: 040 4010 1015
 Service Call Centre: NORTH: 99100 25721, EAST: 84200 59909, WEST: 90821 04420,
 SOUTH (AP, TN): 78939 22727, SOUTH (KA, KL): 90080 65829